

# Maximizing Legacy and DOCSIS 3.0 Bandwidth

Jeff Finkelstein, Cox Communications  
John T. Chapman, Cisco Systems, Inc.

**your friend** in the digital age®

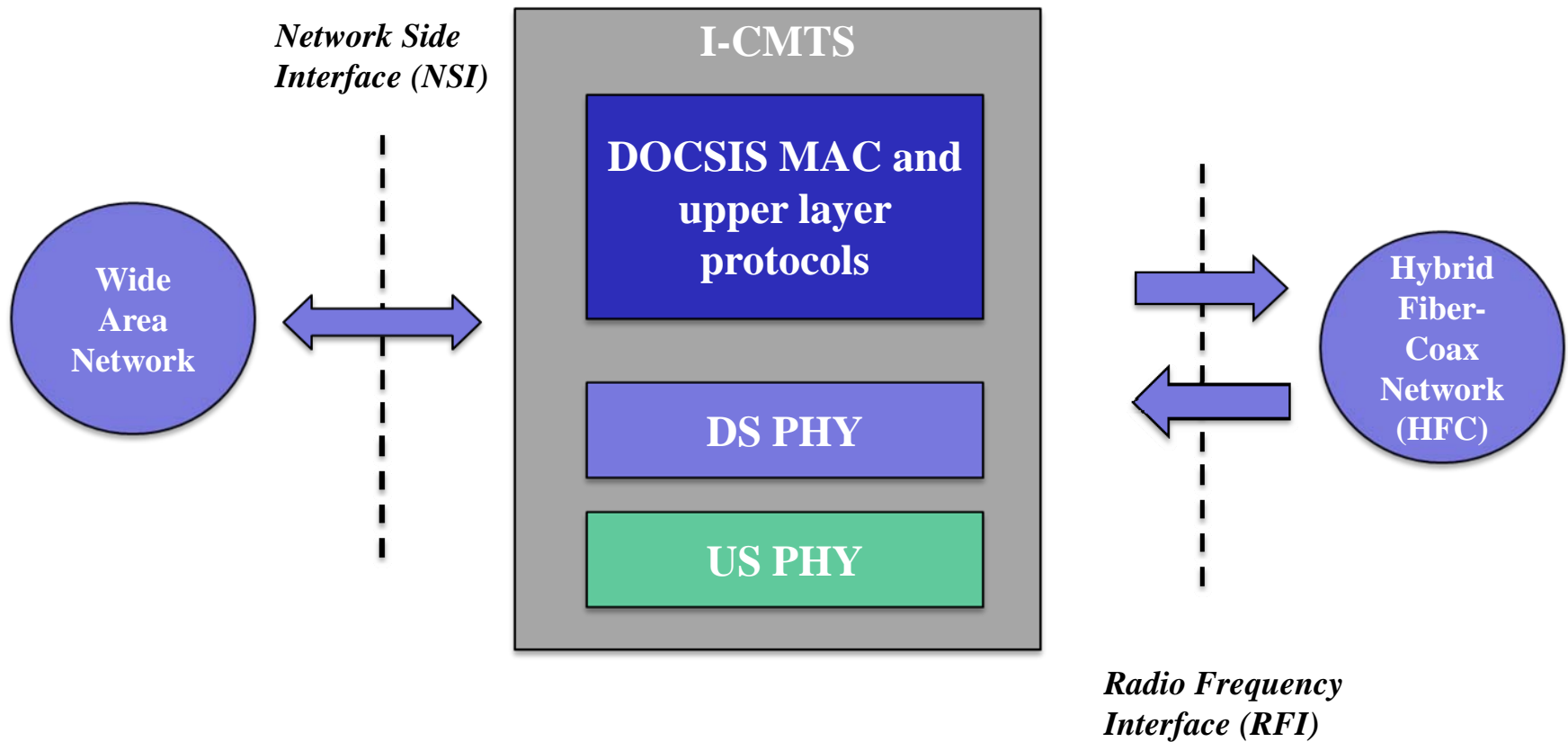



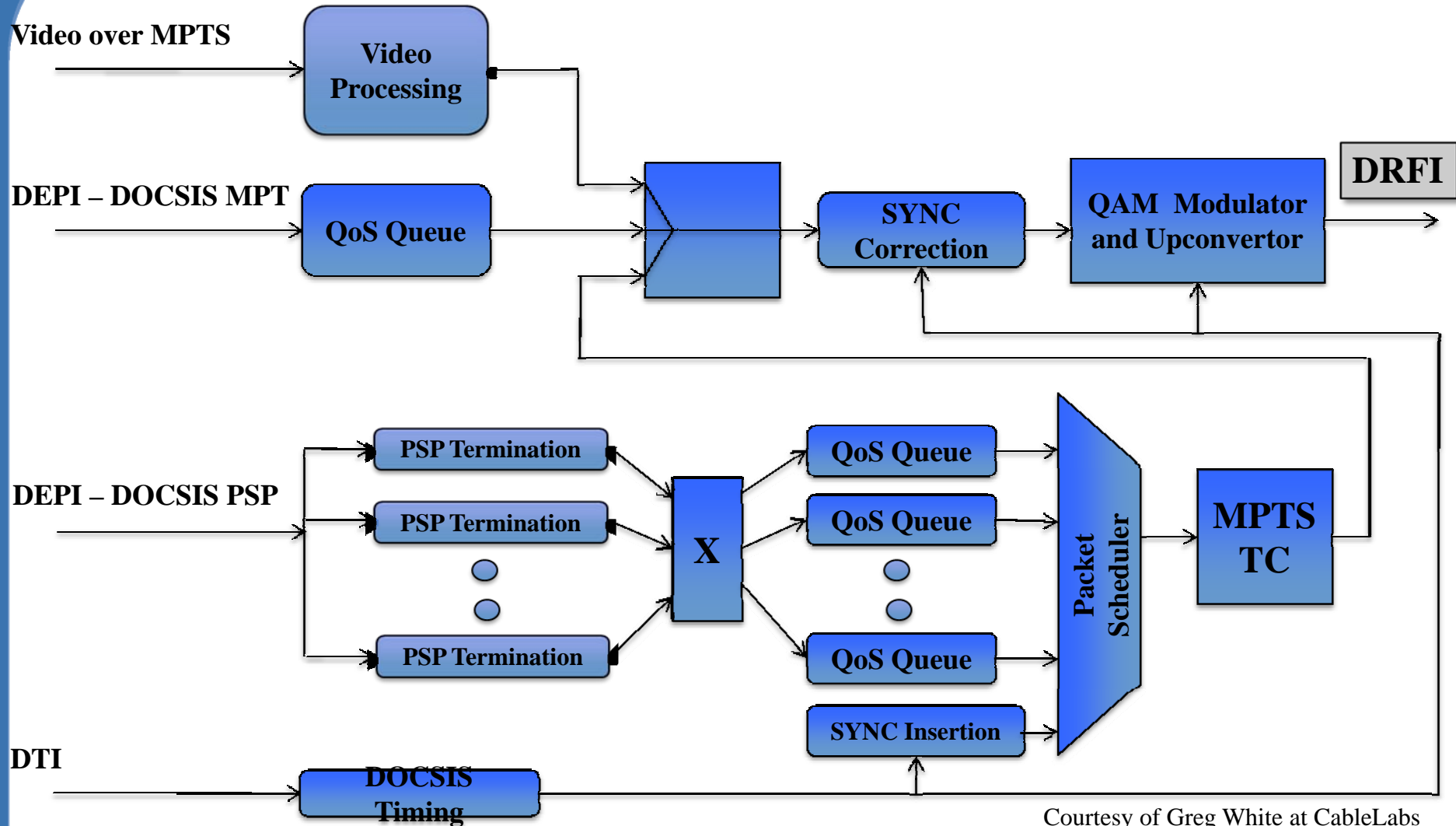

Courtesy of Greg White at CableLabs

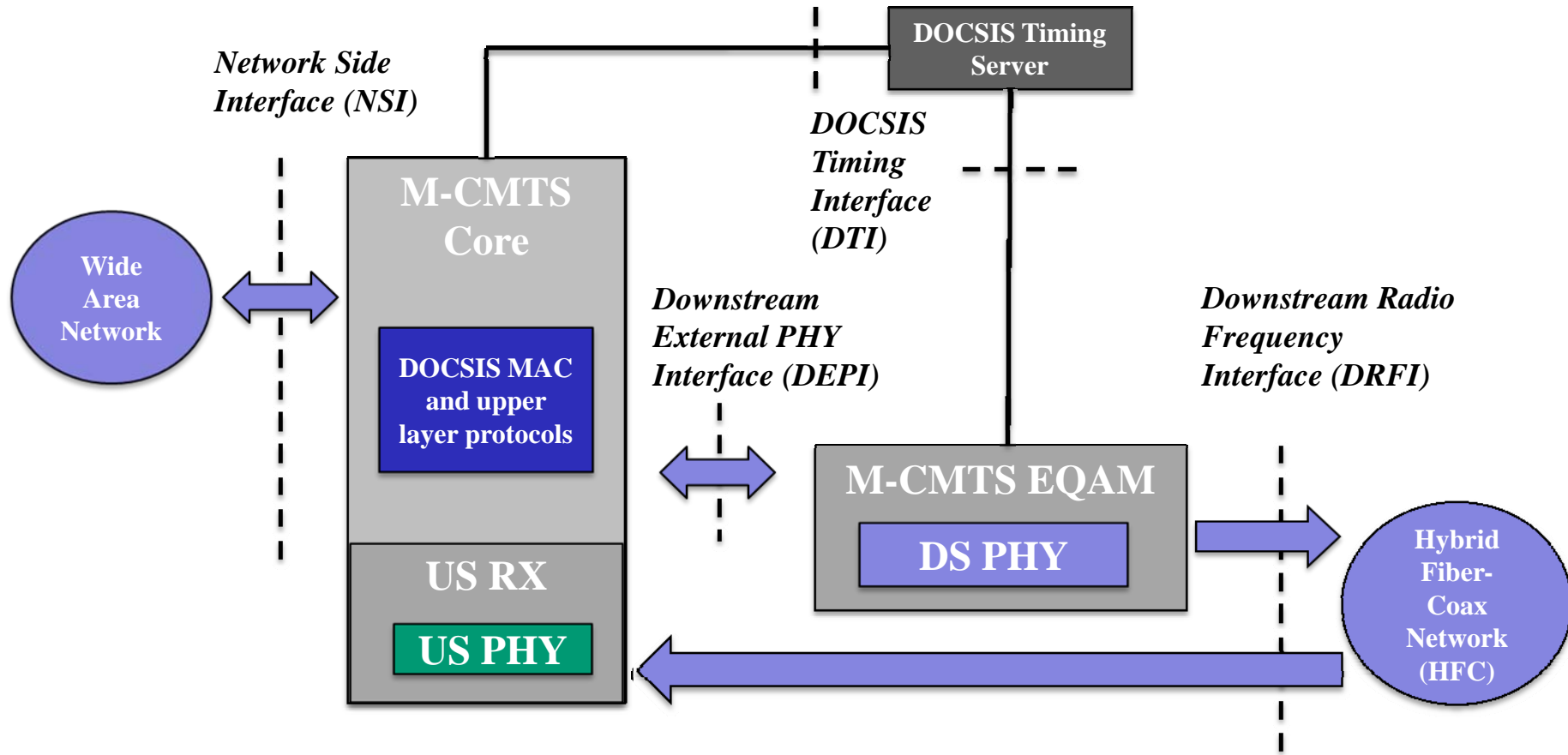

# Adding Capacity to 1 Service Group with 2 Nodes per SG with Dedicated WB Channels

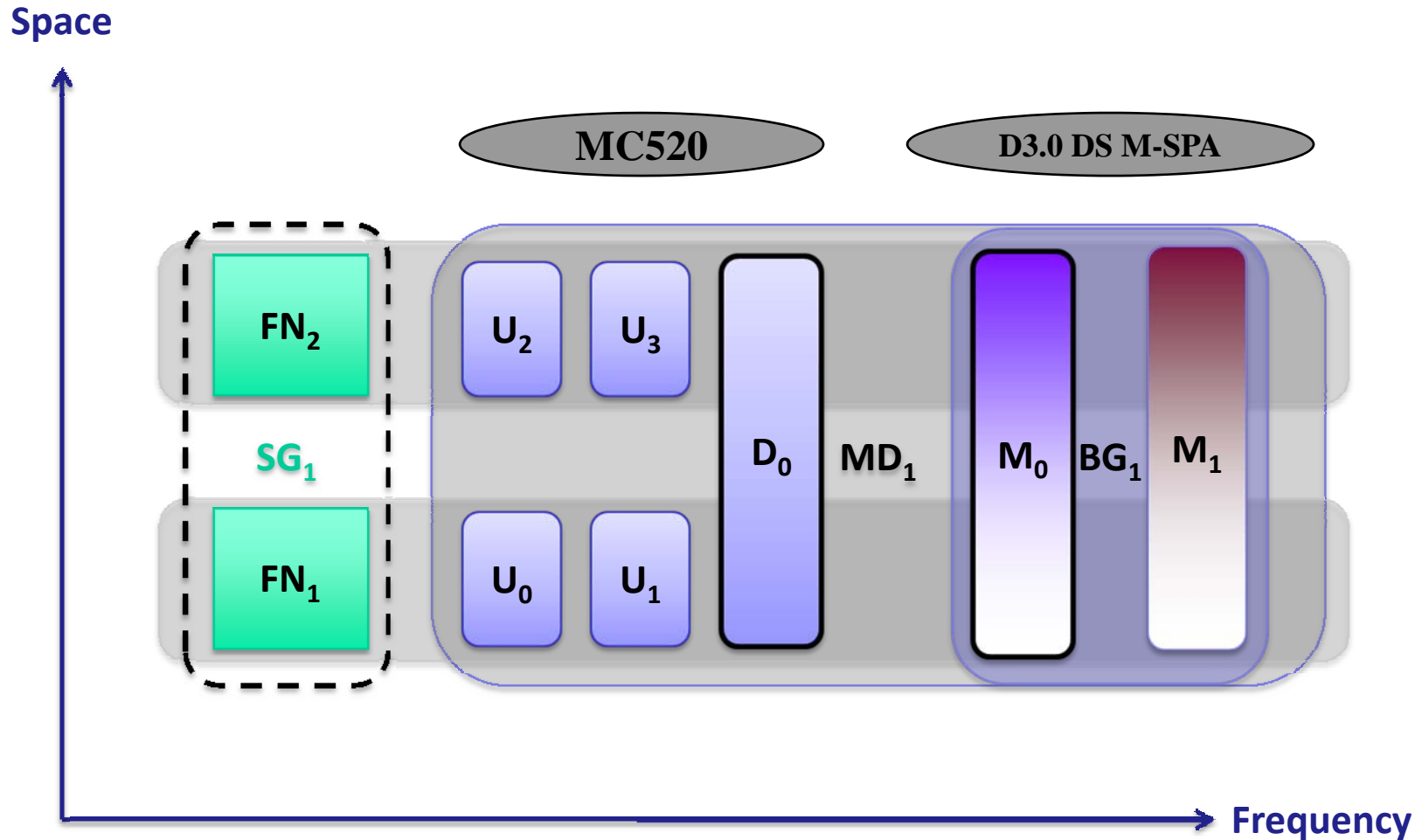

Space

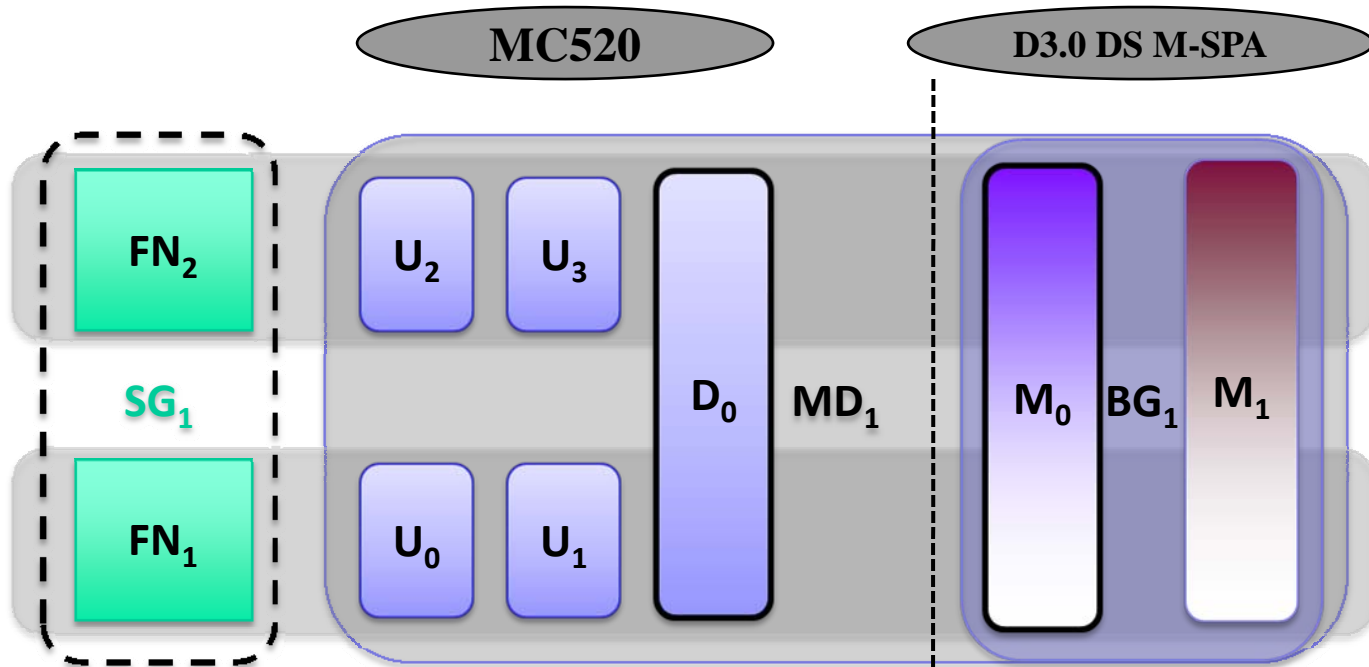

860MHz

Frequency

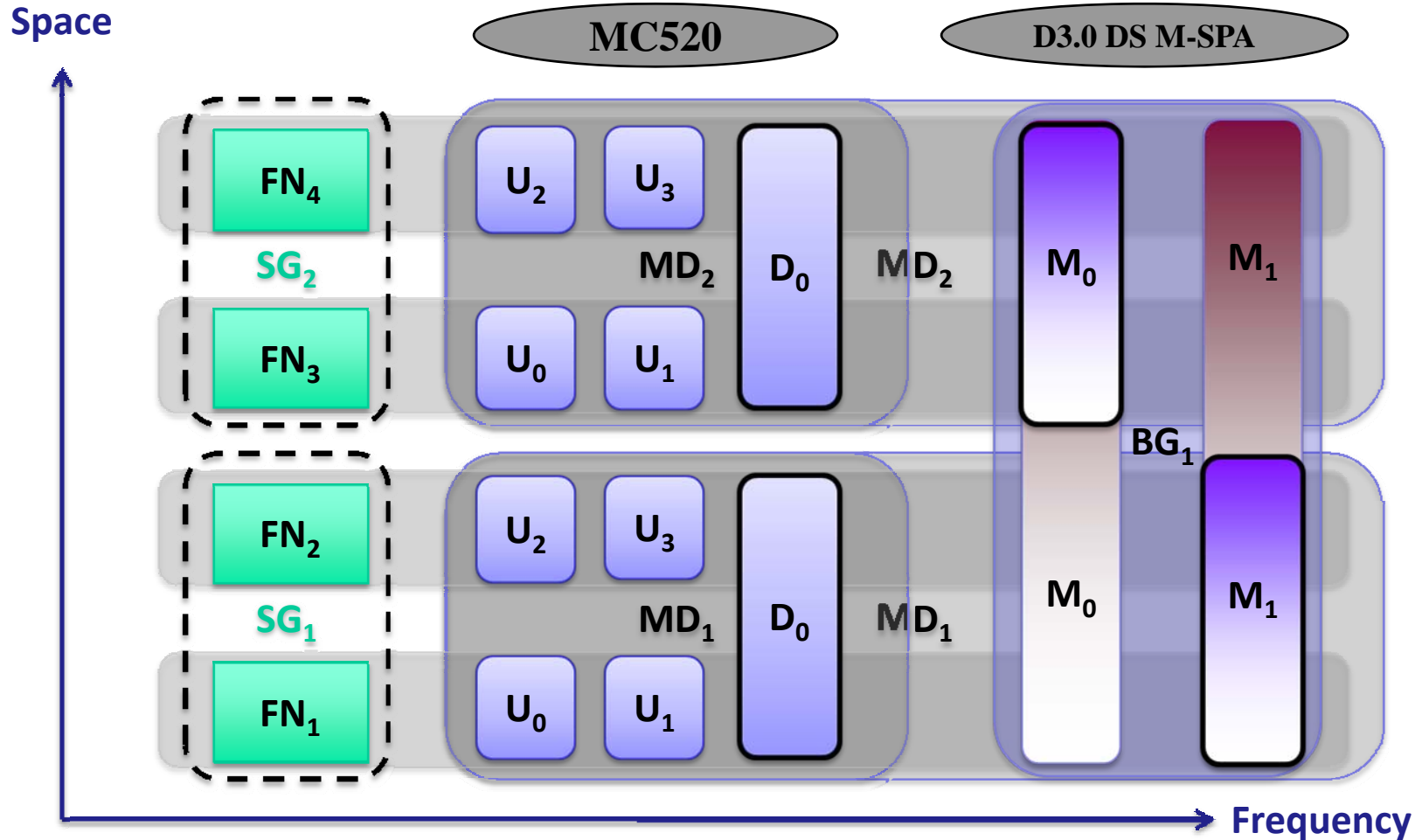

# Adding New Primary Channel Capacity using a Traditional 1x4 MAC Domains

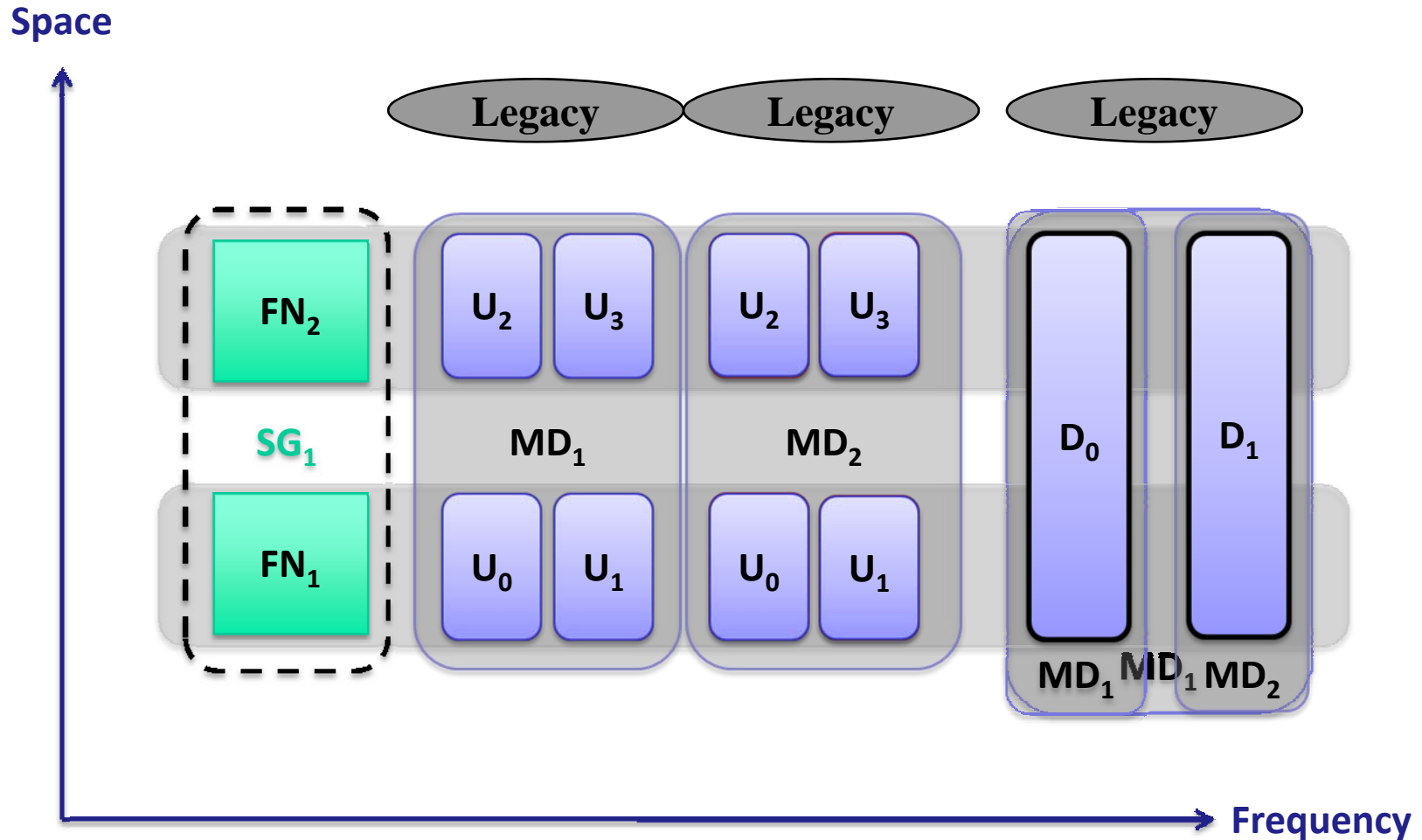

# Adding New Primary Channel Capacity using a DOCSIS 3.0 Downstream

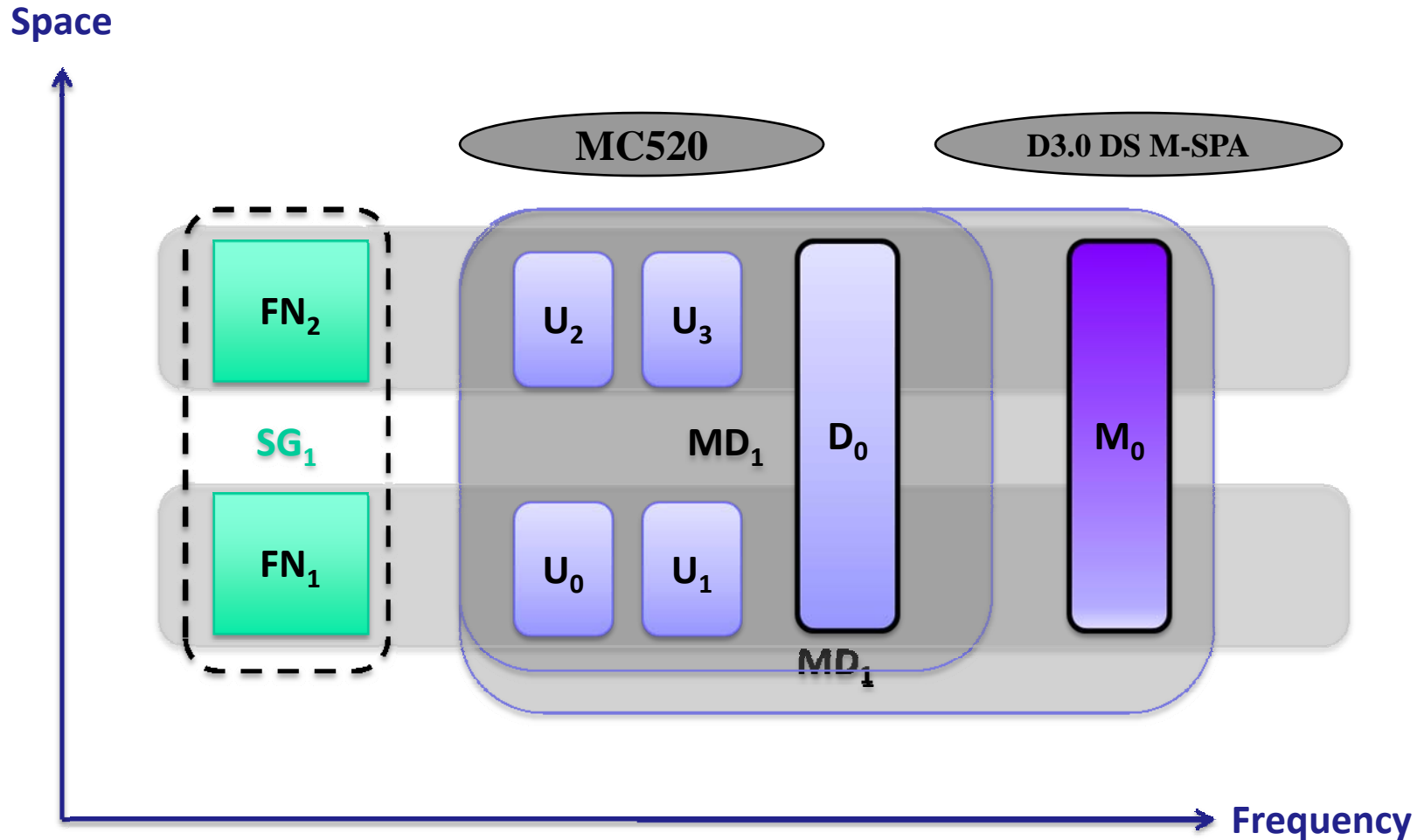

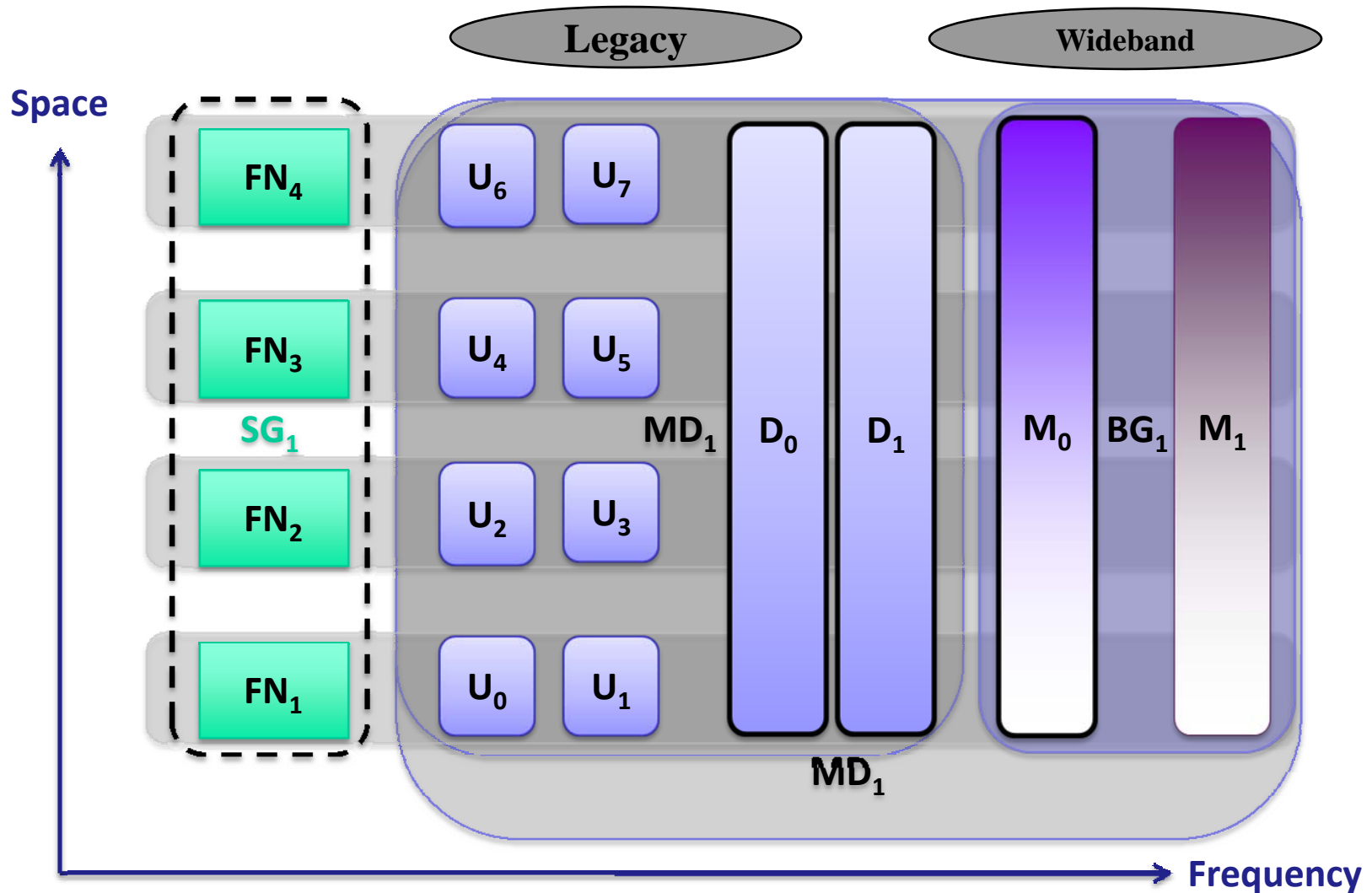

# Converting a 4x2 MAC domain to an 8x2 MAC Domain

Space

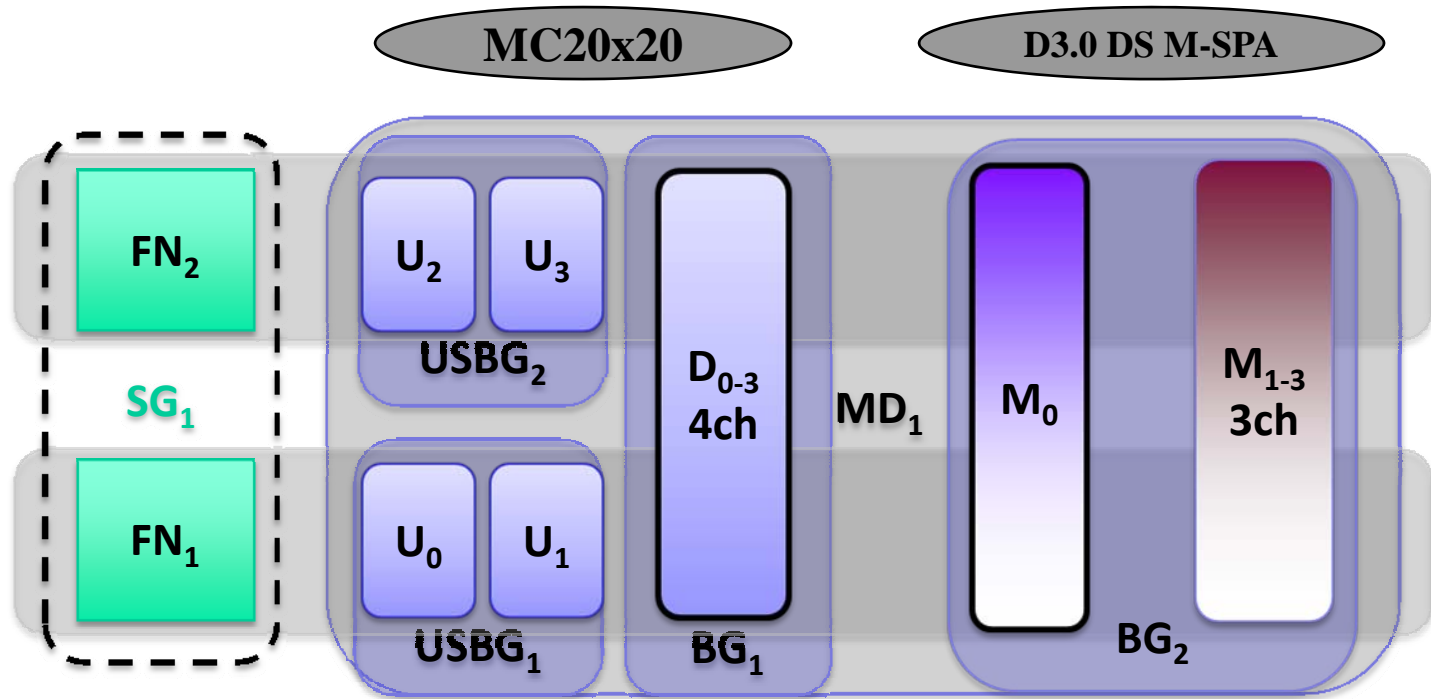

→ Frequency

